

Procedures of Mind

PAUL A. KOLERS* AND HENRY L. ROEDIGER III†

*University of Toronto and †Purdue University

The prevailing metaphor for studies of learning and memory emphasizes the acquisition, storage, and retrieval of "information"; within this framework, mind is often treated as if it were a physical object and information similarly is assumed to have physicalistic properties. Evidence that supports a more process-oriented view of information processing is offered. Mind is described in terms of skill in manipulating symbols and the notion of skills is shown to provide a useful framework for accounting for significant aspects of cognitive processes. Evidence supporting the procedural view includes studies that show that the means of acquisition of information form part of its representation in mind, that recognition varies with the similarity of procedures in acquisition and test, and that transfer between tasks varies with the degree of correspondence of underlying procedures.

Thirty years ago the central textbook of human learning was McGeoch and Irion's (1952) *The Psychology of Human Learning*. The primary concerns of the book were the acquisition, retention, and transfer of verbal lists. There is almost nothing in the book about mind, mentation, information processing, cognition, or even memory. The contemporary scene is different. The intervening years have seen the development of richly elaborated models of mind, information processing, language, and the like—a development that might be considered almost a reaction to the spare and cognitively desiccated notions of McGeoch and Irion.

We believe that the reaction may have gone too far and that current concerns with cognition and information processing have developed too rich a description of mind

and its operations. In the present paper we first survey some of the assumptions that underlie modern work in learning and memory and point out what we consider to be some of their weaknesses—particularly the assumption of static representations. We then propose an alternative view based on the functions or activities of mind as forming the basis of knowledge. In the end we apply this view to a number of memory phenomena of interest to contemporary investigators. Many of the ideas expressed in these proposals, and the theory of symbols on which they are based, were developed more formally in a previous paper (Kolers & Smythe, 1984). Here we are more concerned with empirical justification of the claims.

CONVENTIONAL ASSUMPTIONS OF MEMORY THEORIES

If one asked an intelligent layperson what memory was, more than likely the answer would be something like a place in the mind where information is stored. This actually is the implicit theory embodied in everyday language (Lakoff & Johnson, 1980; Roediger, 1979). Mental processes are often described as objects or events in an actual physical space, as when we speak of

We thank the editor, F. I. M. Craik, for the invitation to prepare this article. Its preparation was supported in part by Grant A7655 from National Science and Engineering Research Council Canada to P.A.K. and in part by Grant R01 HD15054 from the U.S. National Institute of Child Health and Human Development to H.L.R. Requests for reprints should be addressed to Paul A. Kolers, Department of Psychology, University of Toronto, Toronto, Ontario M5S 1A1, Canada, or Henry L. Roediger III, Department of Psychological Sciences, Purdue University, West Lafayette, IN 47907.

storing and *organizing* memories, of *searching through* them, or of *holding* or *grasping* ideas in our minds; like objects, memories may be *lost* or hard to *find*, and so on (Roediger, 1980b). (Whorf, 1956, proposed that such descriptions might be intrinsic to European languages.) In this section of the paper we discuss these and some other assumptions prevalent in many of the theories of memory developed since publication of McGeoch and Irion's (1952) book. Some of these assumptions have a much longer history than is represented by theories of the modern era, but we will confine our remarks largely to contemporary accounts.

1. Spatial Storage and Search

About 75% of the analogies used as models of memory assumed spatial storage and search (Roediger, 1980a), from Aristotle's notion of memory as a wax tablet on which experience writes, to James's (1890) analogy between remembering something and searching a house for a lost object, and Murdock's (1974) notion of memory as a conveyor belt on which information is stored in packets that recede in time. The computer analogy to mind is still another example (Simon, 1979). The spatial array and various buffer storage systems of the computer have been co-opted as models of the human mind, where "information retrieval" is accomplished by search of the memory stores (Anderson, 1983; Atkinson & Shiffrin, 1968; among others). A distinction between place and content, common to computer structures, is also found in these models. However, the fact that some structure is used as part of a computer's operation is not a compelling reason for supposing that it appropriately describes functions in the human mind. Analogy is not by itself an explanation. There is little reason to think that a computer's electronic circuitry provides a hardware model of the brain, and there is no more reason to assume that its software models the mind.

2. Structure-Process Distinction

Tulving and Bower (1974, p. 265) remarked that "A long tradition has held that 'contents' of the mind in some sense exist independently of the 'processes' that create the contents, change them, and make use of them. Thus, in studying memory we are concerned with two broad questions: what the structure of a memory is, and what processes operate upon it." The structure-process distinction follows from a notion of a trace stored in a place, but it has not always been a productive metaphor and may even be unnecessary, as we show later.

3. Structure

When hypothetical structures were first reintroduced into psychology they were used sparingly and only after several lines of behavioral evidence for them were developed (Garner, Hake, & Eriksen, 1956; Miller, 1959). Such restrictions have often been abandoned in recent work and mental structures are introduced with little if any supporting evidence. The upshot is that cognitive psychologists stuff the human mind with metaphorical structures. A recent example, from a text by Dodd and White (1982), is reproduced in Figure 1. According to the text caption it represents "a working general model of the human information processing system." It should be realized, however, that nothing "works" in such a system; the boxes contain only names, not descriptions of processes or relations among them. Kolers and Smythe (1984) called such instances nominal models, in contrast to relational and systematic models, where more effort is directed at operationalizing terms. Many other instances exist in the current literature. For example, in Raaijmakers and Shiffrin's (1980, 1981) search of associative memory (SAM) model the second of five "guiding principles" is the following statement: "Long term memory is a richly interconnected network, with numerous levels, stratifications, categories and trees

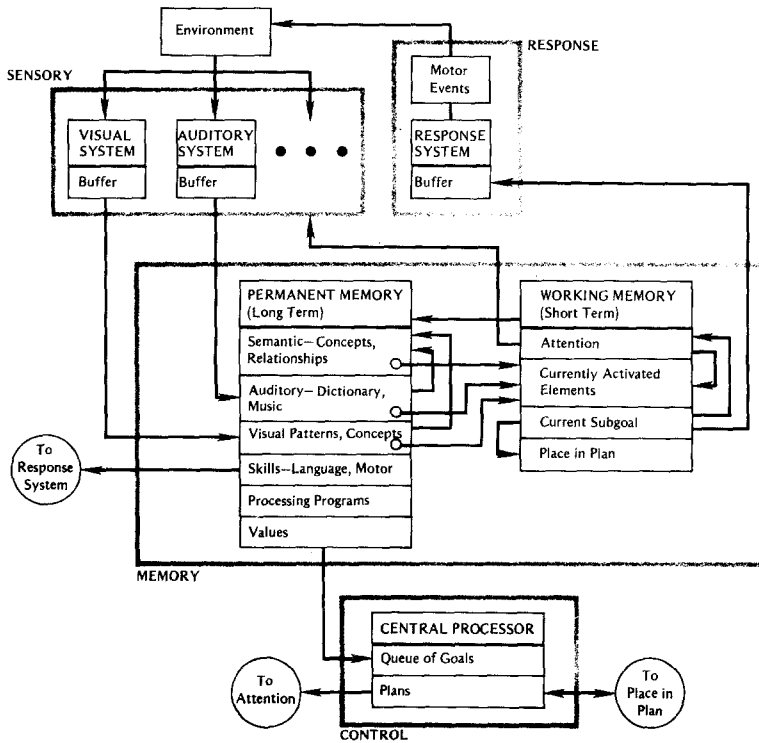

FIG. 1. An information processing representation of the flow of information in mind. Reproduced, with permission, from Dodd and White (1980).

that contain varieties of relationships, schemas, frames and associations. Roughly speaking, all elements of memory are connected to all others, directly or indirectly (though perhaps quite weakly)” (1981, p. 120). If everything is connected to everything else, “directly or indirectly,” it is not clear even what needs representing. All such descriptions are little more than fanciful nominalizations, irrespective of the detail embodied in the accompanying propositions. Concerned that models are becoming top-heavy with mental structures that often bear little relation to their data base (Underwood, 1972), some psychologists have recently urged theorists to adopt a more functionalist approach (Jacoby, Bartz, & Evans, 1978; Watkins, 1981; among others).

4. Process

A belief that experience can be represented in mind as a collection of static ob-

jects or traces deployed in a space leads also to the assumption that processes act upon these structures to accomplish the work of remembering and thinking. The operation and coordination of these processes is often charged to an “executive,” but few if any constraints are imposed on the operation of the agents, nor does evidence typically require postulating them.

5. Memory as Conscious Recollection

The methods used to study memory usually test recall or recognition accompanied by the conscious experience of recollection—the rememberer knows that he or she is remembering the experiences in question. Related investigations that study the feeling of knowing experience (Hart, 1965) or the tip-of-the-tongue phenomenon (Brown & McNeill, 1966) also presuppose conscious monitoring of mental states. These techniques reveal only limited aspects of learning, however; more nearly

complete understanding may require the use of other methods.

Ebbinghaus's (1885/1964) savings technique is one. Kolers (1976) found savings in speed of reading even when subjects failed to recognize the reread pages amid others from the same source; other investigators have reported related phenomena (Cohen & Squire, 1980; Tulving, Schacter, & Stark, 1982). These examples reveal a dissociation between conscious remembering of information and performance measured in other ways, and are discussed more fully below. Conscious recollection may be of only limited importance to many performances in our daily lives, however much it is emphasized in many current theories.

6. *Semantic primacy*

An assumption made in many memory theories is that the representation of the linguistic meaning of events is primary and that other aspects of experience are not coded with, or as durably as, meaning. Thus Craik and Lockhart (1972) proposed that memory was a byproduct of stages of analysis ranging from surface features that were "shallowly encoded" to semantic processing of language that was "deeply encoded." Similarly, theorists concerned with perception of or memory for connected discourse have proposed that what is remembered over longer time periods is the meaning of the material read, divorced from the specific means by which it was acquired (Anderson, 1983; Just & Carpenter, 1980; Kintsch, 1974; Sachs, 1967, among many others). Others propose that faces (and, by extension, other pictures) may be conceptualized as if they were sentences or paragraphs, from which a "gist" or like precis can be extracted (Bower & Karlin, 1974).

An even stronger claim made by many contemporary authors is that all knowledge is amenable, if not to linguistic description, to a language-like propositional representation or other such rule-based system. In

this view a distinct contrast is proposed between mental content and mental process; between "information" (in picture, word, or other medium) and operations upon it. Below we review evidence that challenges these views.

Actually, as Kolers and Smythe (1984) bring out, certain forms of experience do not even lend themselves to linguistic description; they are dense symbols. The perceptual representation of a tree moving in the wind might in some theoretical way be attained by appeal to propositional description. Smells and tastes, however, which form so rich a part of personal experience, may fail even this loose criterion. Neither the mechanisms of smell nor an analytical vocabulary are available for general use; most tastes and smells are referred to by appeal to other objects, such as, "This smells (or tastes) like a . . ."; and when descriptive terms are used, they are vague and imprecise, such as *acrid*, *sweet*, *foul*, *tangy*, *foxy*, *fruity*, and the like (Dravnieks, 1982; Moskowitz, 1981). It is true that we can often pick out by touch shapes that we have seen or pick out by visual inspection shapes that we have touched. But it is also true that we cannot tell how things will taste by looking at them, nor how heavy they will be, nor what they will sound like or smell like—unless, that is, we have experienced those alternatives. The point is that resort to propositional representation encounters difficulties in dealing with ordinary perceptual experience.

These six assumptions seem to be ingrained in conventional ways of thinking about memory. The alternative ideas proposed below do not use any of these assumptions, and yet can account in a general way for many of the important memory phenomena currently being investigated.

A PROCEDURAL ACCOUNT OF PERFORMANCE

Research on learning and memory has preserved a distinction between motor processes and processes based on language or

“thought,” usually with a pejorative implication for the former. The procedural, often regarded as a motor skill, is thought of as more mechanical and uninteresting; the linguistic or related aspects of performance are thought of as more intellectual and important. Procedural or skill learning was often tested by having people trace stars or write while seeing their hands in a mirror, or the like (Hovland, 1951). Language skills were tested by having people learn passages of text, lists of words, associates, and the like. The two enterprises were thought of as separable, although it was never made clear how motor processes were to run off without cognition, or intellectual processes without their motor expression.

Something of the same dichotomy is preserved in the current contrast between declarative and procedural knowledge, or description and action. A debate about whether they are fundamentally the same or whether the two forms of expression differ has exercised a number of investigators of artificial intelligence (Winston, 1977). We note in a related vein that many cognitive scientists seek to represent behavior in a symbol system like that of computer programs (Anderson, 1976, 1982; Newell, 1980); indeed, the fundamental idea is to reduce knowledge to a set of propositions that can be entered into the appropriate simulation or program. In that sort of theorizing a sharp contrast is made between knowledge and its processing, form, or expression.

It is our claim that such contrasts are ill-founded for psychological theory. We will show in some detail that distinctions between mental representation and mental process, between “symbol” and “skill,” are of questionable worth for psychology and may indeed actually misrepresent psychological processes. People can know something visually or tactually or motorically, on our view, without the various kinds of knowing being mappable into each other, let alone being reducible to a

common form. We claim that knowledge of objects is specific to the means of experiencing them.

In asserting our claims we do not deny a contrast between procedural and declarative knowledge, but rather inquire into its present relevance to psychology.¹ A particular feature of the propositionalist view that we dispute is the claim that all knowledge can be represented in the language-like symbols appropriate to a computer program (as in Newell, 1980). Indeed, Anderson (1983) among others seeks to reduce all procedural knowledge to the propositional. This approach misses the fundamental point, however, for there is no trick to propositionalizing. In principle, propositions can be written to any degree of refinement, and without regard to number, to model any process; it is merely a matter of adding statements, of saying something consists of *a* and of *b* and of *c* and of *d* and of *e* . . . , but without necessarily capturing its structure in an intellectually illuminating or efficient way. Our proposal is to do the opposite, that is, to accommodate declarative knowledge in operationalizable terms of actions—the procedures that characterize a person’s acquisition and use of knowledge.

The contrast between declarative and procedural knowledge was developed by logicians to describe forms of statements. Some psychologists suppose that the terms define kinds of memory. Declarative knowledge is identified with semantic memory (Collins & Loftus, 1975) or, in Tulving’s (1983) system, with semantic and episodic memory, and procedural knowledge is iden-

¹ The contrast was introduced in modern times by Ryle (1949) and amplified by Scheffler (1965), among others, as between declarative knowledge (or knowing that) and operational knowledge (knowing how). Scheffler’s useful discussion is based on language forms; for example, upon the way “I know. . .” is completed for statements regarding the value of the square root of 16, or regarding use of a typewriter: the first takes *that* and the second takes *how to* and the terms are not interchangeable without altering meaning.

tified with "skills," which when they do not require "effort" or "attention" are usually thought to run off "automatically" (Hasher & Zacks, 1979; Posner & Snyder, 1975; Wood, 1983). In contrast our aim is to carry forward the attempt to account for *all* of a person's capabilities within the framework of skills or procedures. We will argue that knowledge is a matter of skill in operating on symbols, that the latter are of many kinds, that the kinds are not perfectly correlated, and that knowledge is, as a consequence, means dependent. In the next section we describe some mental events in those terms.

EVIDENCE FOR A PROCEDURALIST VIEW

Reading a text and learning something from it are surely dependent upon "very many of the most intricate workings of the human mind" (Huey, 1908/1968, p. 6). This level of complexity of cognitive performance seems to many investigators to require a fundamentally different account from that assigned to motor skills.

On our account, however, cognitive processes may be well accommodated in procedural terms. We will support our claim by identifying procedural components in behaviors that are of interest to contemporary accounts of learning and memory. The data are derived from experiments using many different dependent measures, including speed of reading, accuracy of report, recognition, recall, perceptual identification, word completion, and lexical decision among them.

Refutation of Semantic Primacy

On a procedural account, knowledge acquired through reading or listening depends on cognitive skills of the perceiver. Application of these skills is often directed at features of the message that most theorists consider superficial—cadence or pitch of a voice, typography, spacing, or orientation of a written text, and the like. Thus, according to the procedural view, and in contrast with some other views, these features

should play a prominent role in forming the representation of the message in memory. However, during the 1960s and 1970s a number of experimenters claimed that features of language related to appearance, such as sound, typography, or the like, were stored only briefly in short-term visual or acoustic memory, whereas the semantic aspects were stored in long-term memory (Bransford & Franks, 1972; Sachs, 1967). Primacy of the semantic component was especially visible in the notions of Craik and Lockhart (1972), in the popular concern with semantic relations, and in the elaborate logical constructions for summarizing the claims due to Anderson (1976), Anderson and Bower (1973), Collins and Quillian (1969), Kintsch (1974), Norman and Rumelhart (1975), and Smith, Shoben, and Rips (1974), among others.²

This concentration upon the semantic aspect of language had a particular perversity to it, however. For one thing, its strong form stripped experience of its perceptual attributes and left the person unable to record in memory the smell of a flower, the look of a face, the sound of music, or other such experiences that resist or often exceed the requirements of a language-like description. For a second thing, this view assumed that its dictionary definition was the most important aspect of a word, and alternate ways of relating to words were usually ignored. In some cases, however, "superficial" features of words are of the greatest interest to understanding, and the words

² By "semantic" we mean the relation between a symbol and its referent. This relation is always specific to a system of symbols. For example, the semantic aspect of the word "chair" is not wholly the same as the semantic aspect of a picture of a chair or of some particular chair or collection of chairs. Our perceptions in the different circumstances are symbolic, of course; the symbols do not overlap perfectly. All of the instances, moreover, have unique uses and capabilities. Some psychologists use "semantic" to mean world knowledge or general interpretation, conceived broadly. Such a usage begs the question of the means of acquisition of particular knowledge and of the relations that develop between systems of symbols, such as between different perceptual modalities.

themselves only one of the means by which such features are instantiated (Eisenstein, 1979; Friedman & Friedman, 1957; Kahn, 1967).

Semantic primacy was refuted by certain sorts of data, as well. An issue of some interest was the duration of the alleged memory that recorded superficial features selectively, and students debated whether material in various short-term memory systems endured for 0.5, for 3, for 10 seconds, and so on (see Crowder, 1976). Several studies carried out at about the same time challenged these claims for a temporal bound on memory for superficial features. Craik and Kirsner (1974) found that people were more likely to recognize words repeated 2 minutes later if they recurred in the same voice than in another voice; and Kirsner (1973) showed that printed words were more likely to be recognized if they recurred in the same typeface than in alternate typefaces. Rothkopf (1971) pointed out that people often remembered a number of superficial or "irrelevant" features of something read, such as the color of a book's binding or the location on a page of a particular item. Geiselman and Bellezza (1976, 1977) demonstrated that people often encoded voice or location of a sound as part of an auditory experience. Several other investigators demonstrated superior memorability of orthographic or phonemic features compared to semantic features, Morris, Bransford, and Franks (1977), Fisher and Craik (1977), Stein (1978), and Zechmeister (1972) among them. Fisher and Cuervo (1983), using bilingual materials, showed that both the language spoken and the gender of the speaker figured in the memory of a passage. In all of these cases location, voice, typography, color, and the like are instances of irrelevant or superficial features, compared to the allegedly deeper semantic features, and whose existence in memory is somewhat incompatible with theories of semantic primacy.

These issues—the duration of short-term memory, the notion that superficial features

were only the carrier of information but played no role in its longer term representation, and the associated notion that only meanings but not means were important—were brought to test by Kolers and Ostry (1974). Building on an earlier study, they required college students to read a large number of sentences singly and, at a later time, to read those same sentences mixed in with an equal number not read before. On the second occasion the students classified the sentences as to whether they had been read before and, if yes, whether their appearance was the same as previously. Appearance was established by orientation of the type. On the first reading half the sentences were right side up, in normal orientation, N; the other half were turned top to bottom around a horizontal axis, I. On the second reading, half of each kind of the first set appeared in the other orientation, making NN, NI, IN, and II pairs, where the letters indicate orientation on each of the two occasions of reading.

On the theory that a superficial feature like typography is stored briefly and only meanings are stored in long-term memory, all of the pairings should have yielded equivalent results for memory; and on the assumption that normal typography provided readier access to the semantics or gist of the sentences, those initially in normal typography should have been recognized more readily on the second reading than those that were initially inverted. The outcome of the tests yielded results contrary to these expectations, however. The findings were that recognition of sentences varied greatly with their orientation, and the sentences initially inverted (II, IN) were recognized more frequently, and with greater accuracy, than the sentences initially in normal orientation (NN, NI). In addition, both inverted and normally oriented sentences were recognized better when they reappeared in the same orientation than in the other one (II better than IN, NN better than NI). The interval of time between first and second readings was not 3

or 10 or 30 seconds, moreover, as in the studies of the duration of "short-term memory," but ranged from about 1 minute to 32 days.

The data were accounted for in terms of analytical activities and procedures. The proposal was that information is acquired from an object by means of pattern analyzing operations that are trained through successive encounters with like objects, and that change with acquisition of skill in a particular analysis. The less skilled a person is, the more detailed analytical work he or she must do to acquire the stimulus; the more analytical work done, the more extensive the person's representation of the stimulus. Normally oriented text is almost transparent to the skilled reader in respect to its familiarity as a visible pattern; inverted text, by virtue of its lesser familiarity, requires substantially more analytical work from the reader than normal text does. The assertion is that disparities in familiar objects attract analytical encoding operations.

Disparities in normally oriented text are usually in its novel message or content, the semantic domain, and so it is that its semantic aspects are usually what are recalled. By turning things around and making the graphemic features the more disparate, Kolers and Ostry also made them memorable. Experiments that show a superior memorability for semantic features may only be special cases of the more general principle that people particularly encode disparities in familiar objects. Disparity or difference of the stimulus from the practiced skill is thus shown to be an effective variable controlling performance.

On this account knowledge is expressed in activities, techniques, procedures—skilled ways of relating to the stimulus—and these ways or activities change as a function of practice or exercise. A counter-intuitive prediction from these claims is that as skill at encoding increases, memorability of the encoded items should decrease. Exactly this outcome was obtained

(Kolers, 1975a). But this issue too is complex.

The notion of disparity of the stimulus requires careful definition. Not all differences matter, and too much detail can incapacitate the person by overloading the system with masses of poorly referenced analysis. For example, if skilled readers of English who are ignorant of a particular foreign script are asked to scan or examine it, they find its disparities too many or too detailed to encode usefully, and subsequent recognition suffers (Kolers, 1974; see Goldstein & Chance, 1971, for related observations). The way that memorability changes as a function of a person's acquiring skill with a symbol set remains to be worked out. In light of experts' performance, it seems plausible that memorability is a U-shaped function of skill, increasing again as skill becomes expertise. Studying transfer of training can play an important part in determining these changes, as we show later.

Means-Dependent Knowledge

The line of experimentation that emphasized the encoding of semantic attributes in preference to physical details of the stimuli made the claim especially strongly that people learn from various media by abstracting and storing their contents, meanwhile discarding source information about the media except perhaps for "footnotes" (Bransford & Franks, 1972; Kintsch & Monk, 1972; Kolers, 1966; Sachs, 1967). This line of work characteristically ignored the means by which information was acquired, but a number of studies since have shown that means and content cannot be wholly distinguished (Kolers, 1978); rather, the means of acquisition, even motoric means, often form a part of whatever a person knows.

We take a few examples from the literature on perception and literacy. A demonstration by Wertheimer (1912/1961) was modified by Pomerantz (1970) to illustrate that motor actions are integrated into per-

ceptual experiences. If the two diagonals of an \times are flashed alternately with a concentric plus sign (+) at the appropriate rate, the entire shape seems to rotate in a compelling motion. Pomerantz added circles at the end points of all the lines and instructed the subjects to scan from circle to circle in a clockwise direction, in a counterclockwise direction, or to fixate the center of the display. Perceived direction of motion of the display tended to follow the direction of scanning eye movements. The display seemed to rotate clockwise when the people scanned clockwise, to rotate counterclockwise when they scanned oppositely, and to "flap its arms" when people fixated the center. Here is evidence that the motor process of directed eye movements entered into the perceptual experience.

Kolers (1969) required people to name words of scrambled sentences leftward or rightward. The scrambling distorted syntactic sequences, and so people were obliged to look at the words one at a time. Nevertheless, the words were named far more rapidly in the familiar rightward direction than in the less familiar leftward direction. The influence of direction of scanning was so strong that even when the word order was nonsense rightward and sensible leftward people could still read more rapidly in the familiar rightward direction than in the unfamiliar leftward direction (an example is provided by rM in Figure 2).

The perceptuomotor sequencing developed by people who read English is not a fixed or rigid pattern, independent of orientation, however. Although rightward is the skilled direction for normally oriented English, appropriate manipulation of the stimulus induces an appropriate transformation of the analytical strategy. Kolers and Perkins (1969) required students to name letters that had been rotated around the principal axes of space. A line of normally oriented letters, spaced singly as r v t d g h, etc., was named reliably more rapidly rightward than leftward; but when the letters were rotated in the plane of the page,

as in R of Figure 2, the rotated letters were named more rapidly leftward than rightward.

Gonzalez and Kolers (1982) examined the issue further in a simple experiment on mental arithmetic. A propositionalist would affirm that numerical quantities are operated upon in mind in some abstracted representation; for example, the reader would evaluate $2 + 3 = 5$ by abstracting twoness, threeness, and fiveness from the numerals and testing the sum in some abstract form of arithmetic. Gonzalez and Kolers suggested, to the contrary, that the operations that mind carries out depend in part on the symbol system within which information is represented. On a propositionalist point of view, the equation above is identical to $II + III = V$, and processing the two forms would be composed of separate stages of acquisition of the symbols and operation on their abstracted content. The latter operation would be identical for the two equations and differences in processing would be attributed only to differences in speed of encoding the symbols. Gonzalez and Kolers showed that differences in processing the equations were attributable not only to acquisition but as well to differences in the operations that were carried out on analog roman symbols that tally quantities and on digital arabic symbols. For example, in equations with mixed symbols ($2 + III = 5$), the placement of the disparate symbol affected performance in important ways. The argument was that the symbols refer in different ways, that mind operates upon them differently in correspondence, and that the operations are carried out upon the symbols rather than upon contents abstracted from them. This interactionist view stands in contrast to one that maintains a structure-process dichotomy and that distinguishes means from knowledge.

Data are not lacking within traditional paradigms to reveal a means dependency of knowledge. Kirsner and Smith (1974) found that two presentations of a word one of which was heard and one read were not as

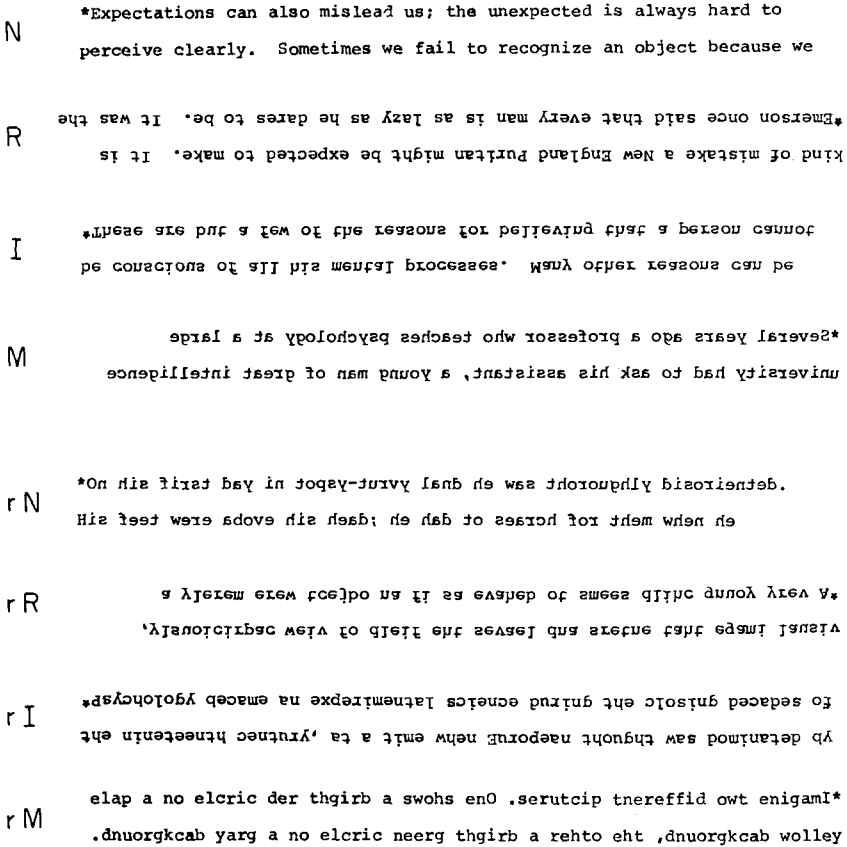

FIG. 2. Eight examples of geometrically rotated texts. The asterisk shows where to begin reading each pair. Reprinted, with permission, from Kolers and Perkins (1975).

effective for memory as two presentations both read. Equivalent limitations on intermodal or interlingual stimulation were reported by Kolers (1975b) and by Jacoby and Dallas (1981). In a lexical decision task Scarborough, Gerard, and Cortese (1979) presented the printed name of objects or line drawings of them and then tested for speed in deciding whether a subsequent letter string was a word. They found considerable facilitation from one presentation of a word to another, but no positive influence of the drawing upon the subsequent response to the word. In a variety of circumstances, we may say, authors have reported lesser influence of one means of presentation upon recognition in another, or lesser influence of information presented in one language upon decisions made in another, than is obtained when both presen-

tations are in the same modality or same language (Kolers & Paradis, 1980). Jacoby and Witherspoon (1982) helpfully survey some more recent evidence to show dependence of recognition upon means of acquisition (analysis) of the stimulus. It is not clear to us how such outcomes can be accommodated within the theory of amodal representation of information; but all of these outcomes are compatible with the notion that the operations carried out in acquiring a stimulus or the means exercised in doing so are part of what one knows about it.

Kolers and Smythe (1979), in an extended review of the imagery debate, also proposed that the operations of mind varied with the contents operated upon and that it was mistaken to try to distinguish a representation from a process operating upon it.

Rather, as the experiments cited above suggest, acquisition and processing of symbols are part of a single indivisible operation. A distinction between structure and process has prevailed in psychological theorizing for quite a long time, but evidence against its legitimacy seems very strong.

Specificity of Transfer

Transfer of training is a venerable topic in psychology, but its course has taken two different directions. One set of students has studied transfer of motor skills from one event to another (Adams, 1976; Magill, 1980). The other line of endeavor studied transfer of training as a function of the formal similarity of items, usually two lists. Investigators counted discernible or denominated features in lists of nonsense syllables, and measured transfer effects from training on one list to learning another (Martin, 1965; Osgood, 1949).

We use the notion of transfer of training in still a third sense, as in the following description. One group of students read 15 passages of inverted text (I in Figure 2) and a second group named its letters, which had been scrambled haphazardly (Kolers & Magee, 1978). The two groups were thus exposed to exactly the same set of mis-oriented characters during training with exactly the same frequency. Following the training, both groups read 10 passages of text as a test and then named one passage of scrambled letters. The curves in Figure 3 bring out several relations. One concerns speed of performance during training and test: The group trained on text improved in speed of performance throughout and read the 10 test pages, passages 15 to 25 on the abscissa, faster than the group trained on letters. A second relation of interest is that the group trained to name letters named a final passage of letters at their former speed, whereas the group that had just read 25 pages of inverted text named individual letters only a little faster than the letter-trained group had done initially—26 on the abscissa.

The findings may be summarized by saying that people read a passage faster than they named its letters (not a surprising finding), that naming letters provided only modest transfer to reading, and that reading provided even less transfer to naming individual letters. These differences can be seen by comparing points in Figure 3. After naming 15 passages of letters, the students read their first page of inverted text at about the speed the text-trained group achieved initially after reading only 4 pages; and after reading 25 pages of text the text-trained students named a passage of letters at about the speed the letter-trained group achieved after about 3 passages. The results (like many others) decisively challenge the theory of reading based on the alphabetic principle, that reading is largely a matter of concatenating letters; more to the present point, the results show that letter identification and word identification are based on particular and specific aspects of pattern recognition, and with only limited transfer between them.

Neither exercise of muscle groups nor formal similarity of items constitutes the basis of transfer in the present case for, surely, reading an unfamiliar typography is not principally a matter of muscle control or of learning lists of nonsense syllables. We propose that positive transfer occurs in relation to the similarity of procedures that two tasks exercise, and we explore aspects of the specificity in the next section.

Transfer versus Dissociation of Skills

On the classical theory of memory a single trace was laid down that represented an experience wholly (Gomulicki, 1953). The notion that experiences can be represented in mind on a unitary dimension is still preserved in some theorizing (Wickelgren, 1973). This approach seems unable to deal with asymmetrical transfer, the unequal influence of training tasks on each other (for example, Kolers & Perkins, 1975). An alternative contemporary view proposes that events are decomposed by

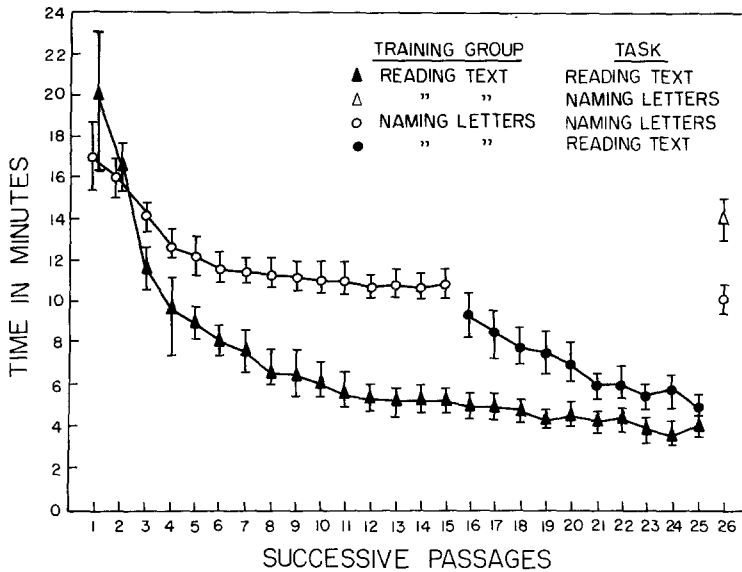

FIG. 3. Differential training and differential transfer after exposure to "identical" stimuli. Copyright (1978) Canadian Psychological Association. Reproduced, with permission, from Kolers and Magee (1978).

sensory processes into distinguishing features, and the features are stored as aspects of the memory trace of the event, usually in a language-like form (Bower, 1967; Underwood, 1969). Other approaches have studied false recognitions (Underwood, 1965), release from proactive interference (Wickens, 1972), and effectiveness of retrieval cues (Tulving & Watkins, 1975), among other tasks that are thought to reveal the selective influence of past experience on perception and memory (Tulving & Bower, 1974). Within this history of endeavor, no agreed upon technique has yet been established for specifying the means by which features are selected for memory, nor has a technique been devised for conclusively determining the attributes of memory traces. The reason for these failures may be that memory has been studied mainly in terms of descriptions of knowledge regarded as the contents of mind rather than in terms of the procedures used to acquire or express knowledge.

Our view is that the effects of experiences depend upon the procedures used to realize them rather than upon some description of them, and that particular ex-

periences train skills selectively. We discuss this broad proposition by reference to some special studies. The issue of interest concerns dissociability of components of performance. If mind contained a single trace of an experience that varied only in strength, then various measures of memory or knowledge would be affected in the same way. The finding has been, rather, that different test performances reveal differential memorability of an experience. For example, Kolers (1975a, 1976) studied people's acquisition of skill at reading geometrically inverted text and its savings and transfer after a year. Some of the passages read on the second occasion had been read also on the first occasion, whereas others, taken from the same sources, had not been read before. Analysis revealed that the re-read pages were read reliably faster than the companion pages read for the first time. The students subsequently classified a large number of these and other pages as new or as having been read before; and if read before, when and how often. Thus three independent measures of performance and an associated one were obtained: speed of reading, and judged familiarity, frequency,

and recency of encounter. People were often able to reread a page faster than they read a companion page but not recognize it as having been read before, or people knew when or how often a page had been read but without any corresponding change in their speed of reading. The various performances were thus said to be dissociated, in analogy to the distinction drawn in the clinical literature (Rapaport, 1951). The dissociations in the present case were between descriptions of a text or of encounters with it, and skill in reading it.

Jacoby (1983) provides another instance. He found that antonyms generated by a person were more likely to be detected in a recognition test than were the same words read from a screen (as did Slamecka & Graf, 1978); but words that had been read were more likely to be identified later from a brief visual presentation than were the same words that had been generated and spoken originally but not read.

The notion of dissociation of task performance has attracted considerable attention in the modern study of memory, both among clinical investigators (Squire, 1982; Warrington & Weiskrantz, 1970, 1974) and others (Jacoby & Dallas, 1981; Tulving et al. 1982). How best to understand such dissociations is currently under discussion. One way of interpreting them is by attributing different aspects of performance to different memory "systems." Tulving (1983) recommends this approach and attributes some aspects of performance to an "episodic" system and some to a "semantic" system. If the occasion of learning forms part of the knowledge, the knowledge is said to be in the episodic system, whereas if the knowledge is independent of the occasion of its acquisition, the knowledge is said to be in the semantic system.

Unfortunately for the argument, this approach lacks a clearly derived means of distinguishing episodic from semantic memory tasks; moreover the contrast of occasion-dependent and occasion-free knowledge lends itself to confusion even at the empir-

ical level. For example, Tulving et al. (1982) found that an episodic presentation facilitated performance on a semantic word completion test, but as the advantage did not decay with time in a manner common to other episodic tasks, the behavior was attributed to a third, "procedural," memory system. Tulving (1983) invokes a distinction between procedural and declarative systems, nests episodic and semantic memories within the declarative system, and assigns "skilled" aspects of performance to the procedural system; but even this complicated arrangement seems poorly justified. Unless the boundaries of tasks said to be episodic, semantic, or other can be established, little conceptual gain accrues from Tulving's analysis, and we may anticipate the invention of still more memory systems to explain still other dissociations encountered experimentally. In illustration, Moscovitch (1981) argues for a multiplicity of dissociations among various capabilities, and Cohen (in press) argues for a multiplicity of memory systems. It is not certain that much is gained by postulating independent "systems" responsible for each sort of memory or dissociation.

Zola-Morgan, Squire, and Mishkin (1982) assume that the procedural and the declarative are two fundamentally different ways of representing experience, each with its own type of dissociation. A related proposal has been urged by Cohen (in press). These authors ignore in this approach the fact that creating statements or descriptions for oneself—the declarations of a declarative system—is as much a matter of executing a procedure as is walking across a room or throwing a ball or reading a text aloud. Statements or declarations, therefore, do not fail of procedural representation; indeed, it would be exceedingly difficult for anyone accepting this dichotomy to specify what aspects of reading aloud are only procedural and what aspects of making statements are not procedural. Below we will argue that dissociation does not require a special accounting.

The perceptuomotor skill of reading words is not perfectly correlated with their recognition as having recently been read; independence of the two skills is quite marked (Cohen & Squire, 1980; Jacoby & Dallas, 1981; Kolers, 1976). The claim for dissociation supposes that different effects of performance identify different memory systems (Moscovitch, 1981; Tulving et al., 1982; Zola-Morgan et al., 1982). It could therefore be argued that the perceptuomotor aspects of reading are in a different "system" from the linguistic. Tulving (1979, 1983), actually has defeated such an argument; he reviewed many instances of "dissociation," all within an episodic memory system. If dissociations are found among tests allegedly tapping the same memory system, then the discovery of dissociation between tasks cannot be taken as evidence for different memory systems.

In contrast to a view that emphasizes a proliferation of memory systems, we recommend that dissociation phenomena be viewed as still another instance of the specificity of learning and transfer. On our view "dissociation" is the natural state of affairs, not what needs explaining. This view is illustrated by the following study (Kolers, 1975b).

The experiment required students to read a long list of sentences. In the critical task, the sentences were inverted typographically and reading speed was measured. As "practice" for reading each test sentence each student read the very same sentence in the same typographic orientation, or the same sentence in normal typography, or a close translation of the sentence in French (for bilingual subjects), or the words of the sentence were played through earphones. A propositionalist account would suppose that reading a sentence or hearing its words would transfer equivalently to aid a later reading, as would reading a sentence in French for a skilled bilingual. After all, the variants preserve the same semantic content and, except for the French translation, in exactly the same words. The findings

were, however, that hearing the words or reading them in translation transferred only weakly to the later reading; reading the very words but in a different typography transferred better; reading the very words in the very typography transferred best. The experiment thus created a ranking of influences: a cross-modal presentation (hearing to reading) or a cross-language presentation (French to English)—the semantic component—yielded least transfer; a greater influence was due to the lexical component—the same words read but in a different typography; and the greatest transfer occurred when the same words were read in the same typography. Reading the very same typography activated nearly the very same procedures; reading the same words in a different typography activated fewer procedures in common; and reading translations of words or acquiring the words through a different medium activated still fewer similarities of procedure across the two readings. Thus skill was manifested across occasions in correspondence as procedures were similar across tasks.

Because procedures are task specific, they can readily appear to be "dissociated," as the following shows. Seven groups of students each read 24 pages in one of the transformations illustrated in Figure 2 (Kolers & Perkins, 1975). After training on the 24 pages of a single transformation, all the students read 2 pages in each of the eight orientations illustrated, in appropriately counterbalanced order. The question of interest was the extent of transfer from training on one transformation to test on the others. Those percentages are shown in Table 1. Transfer from training to test on the same transformation was always 100%; if performance on the test transformation was less than performance on the training transformation, transfer was less than 100%, otherwise it was greater.

The rows of the table show the training transformation, and the columns of the

TABLE 1
PERCENTAGE TRANSFER FROM TRAINING TO TEST

Training	Test							Training average
	M	R	rR	rN	rI	I	rM	
I	95	118	97	80	84	100	52	89
rI	92	112	90	82	100	78	72	89
rR	81	84	100	68	56	79	56	74
rM	88	67	70	57	37	44	100	66
R	87	100	70	37	58	44	41	62
M	100	69	71	72	38	28	52	61
rN	82	3	57	100	36	34	20	47
Test average	89	79	79	71	58	58	56	

table indicate performance on the test transformations. Scanning across columns within any row shows that the percentage transfer to any test from any training varied with the test. Scanning down any column shows that the different training transformations affected test performance differentially. In column R, for example, transfer ranged from 118% for training on I (that is, I trained R better than R trained itself) to near zero, 3%, for training on rN to test on R. Readers thus do not merely learn some general strategy of coping with transformations or acquire some general skill of reading them; rather, they acquire particular skills due to the procedures a transformation activates, and transfer those skills to other transformations as particulars. The “anomalous” transfer in which I and rI trained R better than R trained itself is consistent with the theory of component skills that rationalized the data (Kolers & Perkins, 1975, pp. 250f).

Another fact of the table is the notable asymmetry of transfer; as already remarked, training on I transferred to test on R 118%, but training on R transferred to test on I only 44%; training on rM transferred 88% to test on M, but training on M transferred only 52% to test on rM. Many other examples of asymmetry are present also.

In sum, this body of data bears many of the characteristics that are taken as evi-

dence for dissociation in some of the reports mentioned above, asymmetry and specificity of transfer, and interaction of training and test; but here the results are obtained within the same sensory modality and on the “same” task of reading misoriented text. From our point of view, it is more appropriate to examine these results in terms of the operations the reader performs to carry out the tasks than to invent different perceptual states or memory systems to accommodate the “dissociations” in the data. On our view it is not dissociation that needs to be explained, for that is the natural state of affairs; it is the characteristics of tasks—and relations among their underlying procedures—that needs explaining. Responses are specific to skills in manipulating systems of symbols and there is no necessary connection among responses.

Consciousness

As we noted earlier, the greater part of contemporary research into learning and memory seems to study conscious recollection or conscious experience. By this we mean that the primary measures have been recognition or recall of materials consciously perceived or conscious decisions about such materials, and mechanisms proposed have emphasized accumulation and organization of information about stimuli (Mandler, 1980; Tulving, 1983).

We find the emphasis upon description as the basis of knowledge faulty on two counts. One is that descriptions of events rarely if ever tell a person what to do about the events described. The second is that descriptions implicate both a describer and a reader or interpreter of the description—some ego or like processor. (An appeal to an executive ego is also made by Baddeley, 1982, among many others.) It is unclear to us how such an executive improves at a task such as reading, say, except in the doing, or why telling oneself to do better rarely by itself improves performance. Indeed, for reading geometrically misoriented

texts, description of the transformations to the reader or by the reader to himself or herself does remarkably little to aid performance, compared to practice at the task itself. Moreover, people can often carry out a task expeditiously while being unable to report the principle on which it was based (Brooks, 1978; Hull, 1920), and, as we noted in connection with Figure 3, the features of practice that are useful in one context may transfer little if at all to performance in an apparently related task. Of course consciousness can be important to behavior and we do not gainsay its study, but we can emphasize that people carry out many tasks in which neither the performance itself nor the means of its improvement is open to conscious description. Hence, on our view mind is better construed in terms of what it can do than in terms of descriptions of what it "knows."

An instance of the deleterious effects of a concern with conscious content stems from the work on incidental and intentional learning. It was assumed by many experimenters that an instruction to a subject to attend to a particular feature of a stimulus meant that the subject attended only to that feature; other aspects of the stimulus were thought to be peripheral or outside awareness (Craik & Lockhart, 1972). There is no certainty that a subject encoding stimuli is sensitive to the same features or categories that interest the experimenter, and no reason to believe that only the feature to which attention is directed is encoded (Nelson, 1979). The very term "incidental learning" endows the psychologist with the illusory power to decide what is central and what is incidental to processing. Using the term confuses the psychologist's goals in the experiment with a description of the nervous system's operations. What may be "incidental" to the psychologist may be a fundamental constituent of encoding operations, as size, orientation, or typography of a text have been shown to be. Only after appropriate testing has revealed no residues of their influence can one realistically

describe features of a stimulus as incidental to the original task. Moreover, how a person describes an event depends upon the question the person is asked, the vocabulary the person has available for describing the experience, the person's skill in description, and the like.

People do not encode all identifiable features of an event equally, but encode what they have learned how to encode, and their performance changes as a function of encounters with stimuli. (Training can feed back into encoding, of course; for example, a linguist by virtue of training becomes sensitive to many formal "linguistic" features of words.)

The nature of consciousness is not even certain; it has been debated for rather a long time and been given many treatments (Humphrey, 1951). We believe that consciousness can be usefully conceived of in analogy to a sense organ that is responsive to changes in some internal states of the individual. Consciousness, on this account, does not report on what is in the world, but on how the person's sensing organs respond to events; and like a sense organ it monitors selectively. We believe that an approach to behavior put in terms of a person's skills would prove to be more useful inductively than an appeal to "machinery" for manipulating the contents of consciousness, or lists of descriptions of its contents.

APPLICATIONS AND EXTENSIONS

We have reviewed a number of conditions that encourage a view of learning and memory in terms of the operation of analytical procedures directed at the stimulus. We turn now to other phenomena that interest students of learning and memory and show how some of the same notions can be applied there. In doing this we do not affirm that a proceduralist account necessarily accommodates all phenomena of learning and memory; rather, we recommend this general account for its emphasis on measurable activities. We recommend it also on Occam's principle that simpler accounts

should be refuted before more complex ones are entertained.

Cognitive psychologists often factor their field of inquiry into encoding processes, retrieval processes, and their interaction. It should be clear from what has gone before that such a division may not be warranted; for convenience, however, we discuss phenomena sometimes attributed wholly to encoding processes alone, then the conjectured interactions of encoding and retrieval.

Encoding Phenomena

Under this rubric we discuss phenomena associated with the levels of processing framework, the generation effect, and the effect of imagery instructions on memory.

The levels of processing notion has been criticized on a number of grounds that do not need review here (Cermak & Craik, 1979). We mention the issue in the context of asserting that procedures undertaken to acquire a stimulus may fully account for the performances sometimes attributed to "level" of processing. Actually, a number of psychologists have exploited in a number of ways the fact that instructions or intentions can "set" people or direct their encoding or analytical procedures to different aspects of the stimulus, as have Postman and Adams (1956), Posner (1969), and Hyde and Jenkins (1969).

Craik and Tulving (1975) produced a particularly striking example of the effect of instructional set in showing that the frequency with which words were recognized as having been presented earlier varied according to the directions governing their encoding. The argument of Craik and Tulving was that, when judging words for their semantic category, people encode them more deeply and richly than when judging their appearance as typographic objects. In contrast, and as we will discuss again below, Stein (1978) among others has shown that by suitable definition of the task, the graphemic can be made the more important and the semantic less, a point made earlier

by Kolers and Ostry (1974). Actually, the very notion of *level* is suspect. Craik and Lockhart (1972) implied the existence of a fixed scale on which one moved from less to more as one went from graphemic through syntactic to semantic. Of course, no such dimension or scale exists independently of circumstances; what is superficial and what is deep depends not on the stimulus but on skill, purpose, and the way that the stimulus is "taken" (Kolers, 1975a).³

The generation effect (Slamecka & Graf, 1978) is obtained when under instruction a person carries out some productive operation on a linguistic stimulus, in contrast to only reading it, with a consequent advantage to memory. Words that had been generated in response to a riddle, for example, were recalled better than words that were only flashed on a screen (Erdelyi, Buschke, & Finkelstein, 1977). As we mentioned earlier, Jacoby (1983) has pressed the issue further and shown that the actual advantage to reading or generating depends on the degree to which operations required initially match those required at test. The advantage seems to come from repetition of mental actions, not from generating or reading per se. We believe the generation effect can be accommodated by a proceduralist account of learning and memory.

A similar appeal to analytical operations seems to lend itself to many other circumstances. The more analytical work or the more nonstandard the analytical work a person is required to perform in acquiring a stimulus (Bower, 1972), the greater the likelihood of learning. A spectacular use of procedures is found in many of the techniques that are intended as mnemonic aids. In the method of loci, one "situates" objects as one walks along a real or imagined path; the object is recovered cognitively

³ It is not even clear how to compare graphemic and semantic patterns as burdens or costs to encoding. Lacking a scale that provides a measurement common to them both, we cannot directly compare the efficiency of memory for such features, despite some efforts to do so, as by Bransford et al. (1979).

when one recreates in mind the path taken (Crovitz, 1970). Variations of the technique are also useful to memory (Roediger, 1980b; Smith, 1982). Other remarkable cases of memory also seem to yield to an analysis in terms of the operations or procedures that the rememberer engages in (Hunter, 1957; Luria, 1968). It is not a matter merely of quantity of analysis or procedures, as we mentioned earlier—requiring people to analyze stimuli at too detailed a level does not yield superior performance (Kolers, 1974); rather, it is analysis of the stimulus in a manner appropriate to the question asked, that is significant.

Interaction of Acquisition and Test

On our view all performances express the means by which knowledge was acquired; memory is never a matter of descriptions recovered from a static store. Tulving (1979, 1983) has discussed one aspect of the interactive nature of encoding and retrieval, and Bransford, Franks, Morris, and Stein (1979) have contributed the notion of transfer-appropriate processing to emphasize their belief that relevant similarity of conditions of learning and test is the important criterion. Both of these accounts are accommodated by the notion of a procedural correspondence between learning and test circumstances, albeit from different perspectives.

One way of establishing the contrast between episodic and semantic memory in Tulving's (1983) account has to do with the source of knowledge. Information in mind whose access requires recovery of time and place of the experience is regarded as episodic information, and is thereby assigned to a specific memory system. Information in mind that is independent of the occasion of experience is attributed to another, semantic, memory system. There is nothing special about time and place as sources, however. On our view all knowledge is source dependent. If some knowledge were acquired on a number of different occasions, however, time and place might no

longer function productively in recovering that knowledge. The difference is not in the presence or absence of a source, but in the multiplicity of procedural routes the person can use to express the knowledge.

To the degree that situational variables function as an intrinsic aspect of the acquisition of a stimulus, a number of context-dependent phenomena also seem amenable to a proceduralist analysis. The more similar the procedures used during two occasions, such as learning and test, the more successful performance will be at the later occasion (Smith, 1982). This contingency between learning and test has often been demonstrated in the verbal learning literature. Tasks such as paired associate learning and the learning of serial lists have been used as training and the skills acquired have been measured by transfer to other tasks. Hall (1971) surveys a body of literature that shows first that people improve in task-specific ways across a number of trials; that is, people take fewer trials to reach a criterion on successive lists of serial or paired associate learning (learning to learn). The second point is that learning to learn is not some general process, but is specific to the exercise of particular skills. Postman and Schwartz (1964), for example, showed that training on one sort of list learning task transferred better to the same sort of task than to others. Thus, specific skills must be invoked to account for this type of improvement, not just nonspecific factors ("warm up") (Postman, 1982). A related claim seems applicable to many other studies of encoding and remembering (Hung & Tzeng, 1981).

A final example of an apposite explanation of a phenomenon in terms of procedures is Slamecka's (1977) resolution of the problem of seemingly minimal transfer from a serial to a paired associate list. Slamecka (1977) argued that, in addition to simple presentation of the prior item by the experimenter, the part of the stimulus complex that guides responding in serial learning is the subject's act of recalling the item. The

cue to produce *C* in the serial associative chain is not simply the presentation of *B*, but also is the recall of *B* by the subject. Slamecka proposed that the procedures in recall are a significant part of the associative complex that leads to recovery of the next item in a serial list. When Slamecka (1977) arranged conditions to make compatible responses include both the overt stimulus cues and the covert response produced cues, great positive transfer was obtained. Thus a classic problem in the verbal learning tradition was solved by consideration of the procedural cues in the situation; increasing the similarity of procedures in the two tasks increased transfer, as in other examples we have discussed.

Recovery

We began by remarking on the changes that have occurred in the study of learning and memory in the 30 years since publication of the book by McGeoch and Irion (1952); changes that have seen a return of interest in cognitive phenomena. We end now by pointing out that although much has been gained in the interval in respect to interest in mental life as a topic for study, much, too, has been neglected. For example, in his review "Human Learning and Retention" Hovland (1951) included sections on motor skills, transfer of training, and savings, among other topics; relatively few contemporary works consider them. Study of motor skills has become self-contained and somewhat isolated from the broader study of learning and memory (Kelso, 1982; Marteniuk, 1976; Schmidt, 1975; Stelmach, 1978). Savings and transfer of training seem to have faded from view, perhaps unfortunately. (It is true that the greater number of older studies in which these notions figured prominently considered them principally as methods for measuring the interaction in mind of list contents, as in the studies manipulating formal similarity (Hall, 1971; Osgood, 1949).) On our view, transfer of training and savings methods, properly applied, constitute a

fundament upon which to construct an empirically based cognitive psychology. The techniques would be applied as measures of skills acquired in one cognitive task and expressed in performance on another. Degree of transfer from one task to the second or, as in Nelson's (1978) work, the more subtle measurement of savings, can aid in diagnosing the underlying cognitive operations. The idea is that any complex event is composed of a number of component activities, and the more alike they are, the more alike the behavior will be (Kolers & Perkins, 1975). Judicious experimentation may allow one to infer their identity.

REPRISE

We have argued that an appropriate account of mind should be based on the procedures and skills a person brings to bear on cognitive tasks, rather than be expressed in terms of hypothetical contents or structures of mind. Broadbent (1958) proposed that an appropriate analysis of mind would chart the flow of information through various "systems." In the 25 years since, psychologists have produced increasingly elaborate descriptions of such conjectured flows, as in Figure 1. Unfortunately, there is little agreement on which proposed stores or boxes are necessary for the proper description, much less how they should be arranged. Even seemingly simple questions such as whether "mental search" occurs in a serial or parallel fashion has turned out to be remarkably difficult to decide (Townsend, 1974). Lack of cumulative progress in the information processing tradition may be due to an inappropriate framing of the questions at the outset. Asking how information flows through various cognitive systems presupposes that such systems exist and can be validated by behavioral evidence, yet the research record lacks convincing support for these conceptions. It may be more appropriate at this point to admit that many of the assumptions of the information processing approach are either wrong or are not test-

able, and to seek other ways of studying mind. The procedural approach, even in its current state, provides a useful alternative.

Some comment on the strengths and weaknesses of this approach seems in order. It is common to lament the complexity of many phenomena in our field, a point that cannot be gainsaid (Jenkins, 1979). However, treating cognitive processes as skills that transfer differentially to new tasks can serve as a unifying principle to organize patterns of behavior. Second, complex skills can be conceived as composed of simpler components. These components may be trained differentially and organized in various ways as a person copes with particular tasks. An important area of study is the organization and allocation of component skills as a function of practice at a task. Third, the logic of transfer of training can be used to identify and study the component skills, in ways already mentioned. Differential transfer after mastery of a task can be used to identify the components (Kolers & Perkins, 1975), leading to a taxonomy of trainable capabilities. This emphasis on transfer leads to a fourth advantage: a procedural description of mental processes encourages focusing on observables, the actual behavior of a person performing a task. Such an accounting is preferable to description of behavior in terms of metaphysical entities populating the mind.

The procedural approach we have recommended does have its weaknesses, as we are aware. Chief among them is the imprecision of many key statements and the rather loose definition of terms, including even the concept of skill and its components. These may be defined well in a particular situation but general definitions are difficult to achieve. Some colleagues have questioned whether the "theory" is in any real sense testable.

In answer to such queries we make several points. Regarding the definition of skills, we have emphasized throughout that skills are situation specific. We may raise as a conjecture the notion that this speci-

ficity limits the possibility of creating encompassing descriptive statements. "Adaptation," "evolution," and "pattern recognition" are similarly synoptic terms, suggestive of processes but not explicit across instances.

In regard to theoretical precision, we cannot justify being more specific than current knowledge permits, and current knowledge in this area is limited to the work of a few investigators. Many contemporary models are remarkably sophisticated with respect to precision of definition of terms and the mathematization of their relations. However, this precision is often bought at a heavy price, for the models or theories deal with such a circumscribed set of conditions that general statements are precluded. Often the merest broadening of conditions renders the model inoperative. Estes (1982) devised a mathematical representation of similarity effects in letter recognition, but without concern for size, face, orientation, or other such characteristics of letters, yet these are known to affect recognition in important ways (Huey, 1908/1968; Tinker, 1963), as well as affecting judgments of similarity. Murdock (1982) developed a model of recognition complex, its author remarks, almost to the point of inutility but able to deal with only the very simplest memorial circumstances. Mathematical representation does not by itself explain behavior; like any other system of symbols, mathematics only represents relations. It is not obvious at this stage of investigation that such mathematical formalisms possess any conceptual advantage over a straightforward idea expressed in simple prose. However, there is an advantage to working with a metaphor that captures fundamental relations in behavior over a wide range of situations, albeit imprecisely, for that metaphor can be used as a target for formal development and refinement.

Regarding testability, we have reviewed many sorts of empirical evidence that bear on and support the notion of mentation as an activity and remembering as a skill. This

evidence shows that the procedures of acquisition inextricably form a part of mental representation, that procedures are remarkably specific, that they transfer differentially to new tasks, and the like; such demonstrations are the foundation of our claims regarding the propriety of a procedural view.

The study of cognitive processes has become one of the most popular psychological subjects, especially for English-language psychologists, and yet there is little cumulative development in the field. It is very difficult, for example, to establish psychological principles that have generality across many circumstances. Behavior is situation specific, but its description clearly should have some generality. Our proposal is that a proper course for cognitive psychology is the study of mind construed as skill in manipulating symbols. Acquisition of reference (symbol creation), skill in transforming and manipulating symbols (recognition and problem solving), and their application to new occasions (transfer) can provide a basis (Kolers & Smythe, 1984). Mental life is intrinsically symbolic. Study of the procedures realizing the manipulations must necessarily reveal in a cumulative way the significant characteristics of mind.

REFERENCES

ADAMS, J. A. (1976). *Learning and memory: An introduction*. Homewood, IL: Dorsey.

ANDERSON, J. R. (1976). *Language, memory, and thought*. Hillsdale, NJ: Erlbaum.

ANDERSON, J. R. (1982). Acquisition of cognitive skill. *Psychological Review*, **89**, 369-406.

ANDERSON, J. R. (1983). *The architecture of cognition*. Cambridge, MA: Harvard Univ. Press.

ANDERSON, J. R., & BOWER, G. H. (1973). *Human associative memory*. Hillsdale, NJ: Erlbaum.

ATKINSON, R. C., & SHIFFRIN, R. M. (1968). Human memory: A proposed system and its control processes. In K. W. Spence & J. T. Spence (Eds.), *The psychology of learning and motivation: Advances in research and theory* (Vol. 2). New York: Academic Press.

BADDELEY, A. D. (1982). Domains of recollection. *Psychological Review*, **89**, 708-729.

BOWER, G. H. (1967). A multicomponent theory of the memory trace. In K. W. Spence & J.T. Spence (Eds.), *The psychology of learning and motivation* (Vol. 1). New York: Academic Press.

BOWER, G. H. (1972). Mental imagery and associative learning. In L. W. Gregg (Ed.), *Cognition in learning and memory*. New York: Wiley.

BOWER, G. H., & KARLIN, M. B. (1974). Depth of processing pictures of faces and recognition memory. *Journal of Experimental Psychology*, **103**, 751-757.

BRANSFORD, J. D., & FRANKS, J. J. (1972). The abstraction of linguistic ideas: A review. *Cognition*, **1**, 211-249.

BRANSFORD, J. D., FRANKS, J. J., MORRIS, C. D., & STEIN, B. S. (1979). Some general constraints on learning and memory research. In L. S. Cermak and F. I. M. Craik (Eds.), *Levels of processing in human memory*. Hillsdale, NJ: Erlbaum.

BROADBENT, D. E. (1958). *Perception and communication*. London: Pergamon.

BROOKS, L. (1978). Nonanalytic concept formation and memory for instances. In E. Rosch & B. B. Lloyd (Eds.), *Cognition and categorization*. Hillsdale, NJ: Erlbaum.

BROWN, R., & MCNEILL, D. (1966). The "tip of the tongue" phenomenon. *Journal of Verbal Learning and Verbal Behavior*, **5**, 325-337.

CERMAK, L. S., & CRAIK, F. I. M. (Eds.) (1979). *Levels of processing in human memory*. Hillsdale, NJ: Erlbaum.

COHEN, N. J. (in press). Preserved learning capacity in amnesia: Evidence for multiple memory systems. In N. Butters & L. R. Squires (Eds.), *The neuropsychology of memory*. New York: Guilford.

COHEN, N. J., & SQUIRE, L. R. (1980). Preserved learning and retention of pattern-analyzing skill in amnesia: Dissociation of knowing how and knowing that. *Science*, **210**, 207-210.

COLLINS, A. M., & LOFTUS, E. E. (1975). A spreading-activation theory of semantic processing. *Psychological Review*, **82**, 407-428.

COLLINS, A. M., & QUILLIAN, M. R. (1969). Retrieval time from semantic memory. *Journal of Verbal Learning and Verbal Behavior*, **8**, 240-247.

CRAIK, F. I. M., & KIRSNER, K. (1974). The effect of speaker's voice on word recognition. *Quarterly Journal of Experimental Psychology*, **26**, 274-284.

CRAIK, F. I. M., & LOCKHART, R. S. (1972). Levels of processing: A framework for memory research. *Journal of Verbal Learning and Verbal Behavior*, **11**, 671-684.

CRAIK, F. I. M., & TULVING, E. (1975). Depth of processing and the retention of words in episodic memory. *Journal of Experimental Psychology: General*, **104**, 268-294.

CROVITZ, H. F. (1970). *Galton's walk*. New York: Harper & Row.

- CROWDER, R. G. (1976). *Principles of learning and memory*. Hillsdale, NJ: Erlbaum.
- DODD, D. H., & WHITE, R. M. (1980). *Cognition: Mental structures and processes*. Boston: Allyn & Bacon.
- DRAVNIEKS, A. (1982). Odor quality: Semantically generated multidimensional profiles are stable. *Science*, *218*, 799–801.
- EBBINGHAUS, H. (1964). *Memory* (H. A. Ruger & C. E. Bussenius, Trans.). New York: Dover. (Original work published, 1885).
- EISENSTEIN, E. L. (1979). *The printing press as an agent of change*. London: Cambridge Univ. Press.
- ERDELYI, M. H., BUSCHKE, H., & FINKELSTEIN, S. (1977). Hypernesia for Socratic stimuli: The growth of recall for an internally generated memory list abstracted from a series of riddles. *Memory & Cognition*, *5*, 283–286.
- ESTES, W. K. (1982). Similarity-related channel interactions in visual processing. *Journal of Experimental Psychology: Human Perception and Performance*, *8*, 353–382.
- FISHER, R. P., & CRAIK, F. I. M. (1977). Interaction between encoding and retrieval operations in cued recall. *Journal of Experimental Psychology: Human Learning and Memory*, *3*, 701–711.
- FISHER, R. P., & CUERVO, A. (1983). Memory for physical features of discourse as a function of their relevance. *Journal of Experimental Psychology: Learning, Memory, and Cognition*, *9*, 130–138.
- FRIEDMAN, W. F., & FRIEDMAN, E. S. (1957). *The Shakespearean ciphers examined*. Cambridge: Cambridge Univ. Press.
- GARNER, W. R., HAKE, H. W., & ERIKSEN, C. W. (1956). Operationism and the concept of perception. *Psychological Review*, *63*, 149–159.
- GEISELMAN, R. E., & BELLEZZA, F. S. (1976). Long-term memory for speaker's voice and source location. *Memory & Cognition*, *4*, 483–489.
- GEISELMAN, R. E., & BELLEZZA, F. S. (1977). Incidental retention of speaker's voice. *Memory & Cognition*, *5*, 658–666.
- GOLDSTEIN, A. G., & CHANCE, J. E. (1971). Visual recognition memory for complex configurations. *Perception & Psychophysics*, *9*, 237–241.
- GOMULICKI, B. R. (1953). *The development and present status of the trace theory of memory*. *British Journal of Psychology Monograph Supplements* *29*. Cambridge: Cambridge Univ. Press.
- GONZALEZ, E. G., & KOLERS, P. A. (1982). Mental manipulation of arithmetic symbols. *Journal of Experimental Psychology: Learning, Memory, and Cognition*, *8*, 308–319.
- HALL, J. F. (1971). *Verbal learning and retention*. Philadelphia: Lippincott.
- HART, J. T. (1965). Memory and the feeling-of-knowing experience. *Journal of Educational Psychology*, *56*, 208–216.
- HASHER, L., & ZACKS, R. T. (1979). Automatic and effortful processes in memory. *Journal of Experimental Psychology: General*, *108*, 356–388.
- HOVLAND, C. I. (1951). Human learning and retention. In S. S. Stevens (Ed.), *Handbook of experimental psychology*. New York: Wiley.
- HUEY, E. B. (1968). *The psychology and pedagogy of reading*. Cambridge, MA: MIT Press (Original work published 1908).
- HULL, C. L. (1920). Quantitative aspects of the evolution of concepts. *Psychological Monographs*, *28*.
- HUMPHREY, G. (1951). *Thinking: An introduction to its experimental psychology*. London: Methuen.
- HUNG, D. L., & TZENG, O. J. (1981). Orthographic variations and visual information processing. *Psychological Bulletin*, *90*, 377–414.
- HUNTER, I. M. L. (1957). *Memory: Facts and fallacies*. Harmondsworth, Middlesex: Penguin.
- HYDE, T. S., & JENKINS, J. J. (1969). The differential effects of incidental tasks on the organization of recall of a list of highly associated words. *Journal of Experimental Psychology*, *82*, 472–481.
- JACOBY, L. L. (1983). Perceptual enhancement: Persistent effects of an experience. *Journal of Experimental Psychology: Learning, Memory, and Cognition*, *9*, 21–38.
- JACOBY, L. L., BARTZ, W. H., & EVANS, J. D. (1978). A functional approach to levels of processing. *Journal of Experimental Psychology: Human Learning and Memory*, *4*, 346–351.
- JACOBY, L. L., & DALLAS, M. (1981). On the relationship between autobiographical memory and perceptual learning. *Journal of Experimental Psychology: General*, *3*, 306–340.
- JACOBY, L. L., & WITHERSPOON, D. (1982). Remembering without awareness. *Canadian Journal of Psychology*, *36*, 300–324.
- JAMES, W. (1890). *The principles of psychology*. New York: Holt.
- JENKINS, J. J. (1979). Four points to remember: A tetrahedral model of memory experiments. In L. S. Cermak & F. I. M. Craik (Eds.), *Levels of processing in human memory*. Hillsdale, NJ: Erlbaum.
- JUST, M. A., & CARPENTER, P. A. (1980). A theory of reading: From eye fixations to comprehension. *Psychological Review*, *87*, 329–354.
- KAHN, D. (1967). *The codebreakers*. New York: Macmillan Co.
- KELSO, J. A. S. (Ed.) (1982). *Human motor behavior: An introduction*. Hillsdale, NJ: Erlbaum.
- KINTSCH, W. (1974). *The representation of meaning in memory*. Hillsdale, NJ: Erlbaum.
- KINTSCH, W., & MONK, D. (1972). Storage of complex information in memory: Some implications of the speed with which inferences can be made. *Journal of Experimental Psychology*, *94*, 25–32.
- KIRSNER, K. (1973). An analysis of the visual com-

- ponent in recognition memory for verbal stimuli. *Memory & Cognition*, 1, 449-453.
- KIRSNER, K., & SMITH, M. C. (1974). Modality effects in word identification. *Memory & Cognition*, 2, 637-640.
- KOLERS, P. A. (1966). Interlingual facilitation of short-term memory. *Journal of Verbal Learning and Verbal Behavior*, 5, 314-319.
- KOLERS, P. A. (1969). Clues to a letter's recognition: Implications for the design of characters. *Journal of Typographic Research*, 3, 145-168.
- KOLERS, P. A. (1974). Remembering trivia. *Language and Speech*, 17, 324-336.
- KOLERS, P. A. (1975a). Memorial consequences of automatized encoding. *Journal of Experimental Psychology: Human Learning and Memory*, 1, 680-701.
- KOLERS, P. (1975b). Specificity of operations in sentence recognition. *Cognitive Psychology*, 7, 289-306.
- KOLERS, P. A. (1976). Reading a year later. *Journal of Experimental Psychology: Human Learning and Memory*, 2, 554-565.
- KOLERS, P. A. (1978). On the representations of experience. In D. Gerver & W. Sinaiko (Eds.), *Language interpretation and communication*. New York: Plenum.
- KOLERS, P. A., & MAGEE, L. E. (1978). Specificity of pattern-analyzing skills in reading. *Canadian Journal of Psychology*, 32, 43-51.
- KOLERS, P. A., & OSTRY, D. J. (1974). Time course of loss of information regarding pattern analyzing operations. *Journal of Verbal Learning and Verbal Behavior*, 13, 599-612.
- KOLERS, P. A., & PARADIS, M. (1980). Introduction: Psychological and linguistic studies of bilingualism. *Canadian Journal of Psychology*, 34, 287-303.
- KOLERS, P. A., & PERKINS, D. N. (1969). Orientation of letters and their speed of recognition. *Perception & Psychophysics*, 5, 275-280.
- KOLERS, P. A., & PERKINS, D. N. (1975). Spatial and ordinal components of form perception and literacy. *Cognitive Psychology*, 7, 228-267.
- KOLERS, P. A. & SMYTHE, W. E. (1979). Images, symbols, and skills. *Canadian Journal of Psychology*, 33, 158-184.
- KOLERS, P. A. & SMYTHE, W. E. (1984). Symbol manipulation: Alternatives to the computational view of mind. *Journal of Verbal Learning and Verbal Behavior*, 23, 289-314.
- LAKOFF, G., & JOHNSON, M. G. (1980). *Metaphors we live by*. Chicago: Univ. of Chicago Press.
- LURIA, A. R. (1968). *The mind of a mnemonist*. New York: Basic Books.
- MAGILL, R. A. (1980). *Motor learning: Concepts and applications*. Dubuque, IA: Brown.
- MANDLER, G. (1980). Recognizing: The judgment of previous occurrence. *Psychological Review*, 87, 252-271.
- MARTENIUK, R. G. (1976). *Information processing in motor skills*. New York: Holt, Rinehart, & Winston.
- MARTIN, E. (1965). Transfer of verbal paired-associates. *Psychological Review*, 72, 327-343.
- MCGEOCH, J. A., & IRION, A. L. (1952). *The psychology of human learning*. New York: Longmans.
- MILLER, N. E. (1959). Liberalization of basic S-R concepts: Extensions to conflict behavior, motivation, and social learning. In S. Koch (Ed.), *Psychology: A study of a science* (Vol. 2). New York: McGraw-Hill.
- MORRIS, C. D., BRANSFORD, J. D., & FRANKS, J. J. (1977). Levels of processing versus transfer appropriate processing. *Journal of Verbal Learning and Verbal Behavior*, 16, 519-533.
- MOSCOVITCH, M. (1981). Multiple dissociations of function in amnesia. In L. S. Cermak (Ed.), *Memory and amnesia*. Hillsdale, NJ: Erlbaum.
- MOSKOWITZ, H. R. (1981). Psychophysical scaling and optimization of odor mixtures. In H. R. Moskowitz & C. B. Warren (Eds.), *Odor quality and chemical structure*. Washington, D.C.: Amer. Chem. Soc.
- MURDOCK, B. B., JR. (1974). *Human memory: Theory and data*. Hillsdale, NJ: Erlbaum.
- MURDOCK, B. B., JR. (1982). A theory for the storage and retrieval of item and associative information. *Psychological Review*, 89, 609-626.
- NELSON, T. O. (1978). Detecting small amounts of information in memory: Savings for nonrecognized items. *Journal of Experimental Psychology: Human Learning and Memory*, 4, 453-468.
- NELSON, D. L. (1979). Remembering pictures and words: Appearance, significance, and name. In L. S. Cermak & F. I. M. Craik (Eds.), *Levels of processing in human memory*. Hillsdale, NJ: Erlbaum.
- NEWELL, A. (1980). Physical symbol systems. *Cognitive Science*, 4, 135-183.
- NORMAN, D. A., & RUMELHART, D. E. (Eds.) (1975). *Explorations in cognition*. San Francisco: Freeman.
- OSGOOD, C. E. (1949). The similarity paradox in human learning: A resolution. *Psychological Review*, 56, 132-143.
- POMERANTZ, J. R. (1970). Eye movements affect the perception of apparent (beta) movement. *Psychonomic Science*, 19, 193-194.
- POSNER, M. I. (1969). Abstraction and the process of recognition. In G. H. Bower & J. T. Spence (Eds.), *The psychology of learning and motivation* (Vol. 3). New York: Academic Press.
- POSNER, M. I., & SNYDER, C. R. R. (1975). Attention and cognitive control. In R. L. Solso (Ed.), *Information processing and cognition: The Loyola Symposium*. Hillsdale, NJ: Erlbaum.
- POSTMAN, L. (1982). An examination of practice ef-

- fects in recognition. *Memory & Cognition*, **10**, 333–340.
- POSTMAN, L., & ADAMS, P. A. (1956). Studies in incidental learning: IV. The interaction of orienting tasks and stimulus materials. *Journal of Experimental Psychology*, **51**, 329–333.
- POSTMAN, L., & SCHWARTZ, M. (1964). Studies of learning to learn. I. Transfer as a function of method of practice and class of verbal materials. *Journal of Verbal Learning and Verbal Behavior*, **3**, 37–49.
- RAPAPORT, D. (1951). *Organization and pathology of thought*. New York: Columbia Univ. Press.
- RAAIJMAKERS, J. G. W., & SHIFFRIN, R. M. (1980). SAM: A theory of probabilistic search of associative memory. In G. H. Bower (Ed.), *The psychology of learning and motivation* (Vol. 14). New York: Academic Press.
- RAAIJMAKERS, J. G. W., & SHIFFRIN, R. M. (1981). Search of associative memory. *Psychological Review*, **88**, 93–134.
- ROEDIGER, H. L., III (1979). Implicit and explicit memory models. *Bulletin of the Psychonomic Society*, **13**, 339–342.
- ROEDIGER, H. L., III (1980a). The effectiveness of four mnemonics in ordering recall. *Journal of Experimental Psychology: Human Learning and Memory*, **6**, 558–567.
- ROEDIGER, H. L., III (1980b). Memory metaphors in cognitive psychology. *Memory & Cognition*, **8**, 231–246.
- ROTHKOPF, E. Z. (1971). Incidental memory for location of information in text. *Journal of Verbal Learning and Verbal Behavior*, **10**, 608–613.
- RYLE, G. (1949). *The concept of mind*. London: Hutchinson.
- SACHS, J. D. S. (1967). Recognition memory for syntactic and semantic aspects of connected discourse. *Perception & Psychophysics*, **2**, 437–442.
- SCARBOROUGH, D. L., GERARD, L., & CORTESE, C. (1979). Accessing lexical memory: The transfer of word repetition effects across tasks and modality. *Memory & Cognition*, **7**, 3–12.
- SCHEFFLER, I. (1965). *Conditions of knowledge*. Glenview, IL: Scott, Foresman.
- SCHMIDT, R. A. (1975). *Motor skills*. New York: Harper & Row.
- SIMON, H. A. (1979). Information processing models of cognition. *Annual Review of Psychology*, **30**, 363–396.
- SLAMECKA, N. J. (1977). A case for response produced cues in serial learning. *Journal of Experimental Psychology*, **3**, 222–232.
- SLAMECKA, N. J., & GRAF, P. (1978). The generation effect: Delineation of a phenomenon. *Journal of Experimental Psychology: Human Learning and Memory*, **4**, 592–604.
- SMITH, S. M. (1982). Enhancement of recall using multiple environmental contexts during learning. *Memory & Cognition*, **10**, 405–412.
- SMITH, E. E., SHOBEEN, E. J., & RIPS, L. J. (1974). Structure and process in semantic memory: A featural model for semantic decisions. *Psychological Review*, **81**, 214–241.
- SQUIRE, L. R. (1982). The neuropsychology of human memory. *Annual Review of Neuroscience*, **5**, 241–273.
- STEIN, B. S. (1978). Depth of processing reexamined: The effects of precision of encoding and test appropriateness. *Journal of Verbal Learning and Verbal Behavior*, **17**, 165–174.
- STELMACH, G. E. (1978). *Information processing in motor control and learning*. New York: Academic Press.
- TINKER, M. A. (1963). *Legibility of print*. Ames: Univ. of Iowa Press.
- TOWNSEND, J. T. (1974). Issues and models concerning the processing of a finite number of inputs. In B. H. Kantowitz (Ed.), *Human information processing: Tutorials in performance and cognition*. Hillsdale, NJ: Erlbaum.
- TULVING, E. (1979). Relation between encoding specificity and levels of processing. In L. S. Cermak & F. I. M. Craik (Eds.), *Levels of processing in human memory*. Hillsdale, NJ: Erlbaum.
- TULVING, E. (1983). *Elements of episodic memory*. New York: Oxford Univ. Press.
- TULVING, E., & BOWER, G. H. (1974). The logic of memory representations. In G. H. Bower (Ed.), *Psychology of learning and motivation* (Vol. 8). New York: Academic Press.
- TULVING, E., SCHACTER, D. L., & STARK, H. A. (1982). Priming effects in word-fragment completion are independent of recognition memory. *Journal of Experimental Psychology: Learning, Memory, and Cognition*, **8**, 336–342.
- TULVING, E., & WATKINS, M. J. (1975). Structure of memory traces. *Psychological Review*, **82**, 261–275.
- UNDERWOOD, B. J. (1965). False recognition produced by implicit verbal responses. *Journal of Experimental Psychology*, **70**, 122–129.
- UNDERWOOD, B. J. (1969). Attributes of memory. *Psychological Review*, **76**, 559–573.
- UNDERWOOD, B. J. (1972). Are we overloading memory? In A. W. Melton & E. Martin (Eds.), *Coding processes in human memory*. Washington, D.C.: Winston.
- WARRINGTON, E. K., & WEISKRANTZ, L. (1970). Amnesic syndrome: Consolidation or retrieval? *Nature (London)* **228**, 628–630.
- WARRINGTON, E. K., & WEISKRANTZ, L. (1974). The effect of prior learning on subsequent retention in amnesic patients. *Neuropsychologia*, **12**, 419–428.
- WATKINS, M. J. (1981). Human memory and the information-processing metaphor. *Cognition*, **10**, 331–336.
- WERTHEIMER, M. (1961). Experimentelle studien ueber das Sehen von Bewegung. In T. Shipley

- (Ed. and Trans.) *Classics in psychology*. New York: Philosophical Library. (Reprinted from *Zeitschrift fuer Psychologie*, 1912, **61**, 161–265.)
- WHORF, B. L. (1956). *Language, thought, and reality*. Cambridge, MA: MIT Press.
- WICKELGREN, W. (1973). The long and the short of memory. *Psychological Bulletin*, **80**, 425–438.
- WICKENS, D. D. (1972). Characteristics of word encoding. In A. W. Melton & E. Martin (Eds.), *Coding processes in human memory*. New York: Wiley.
- WINSTON, P. H. (1977). *Artificial intelligence*. Reading, MA: Addison–Wesley.
- WOOD, G. (1983). *Cognitive psychology: A skills approach*. Monterey, CA: Brooks/Cole.
- ZECHMEISTER, E. B. (1972). Orthographic distinctiveness as a variable in word recognition. *American Journal of Psychology*, **85**, 425–430.
- ZOLA-MORGAN, S., SQUIRE, L. R., & MISHKIN, M. (1982). The neuroanatomy of amnesia: Amygdala–hippocampus versus temporal stem. *Science*, **218**, 1337–1339.

(Received July 18, 1983)

(Revision received January 17, 1984)